



## Daiken-Mouldings

E0/EPA/CARB

**Daiken-Mouldings** is designed specifically for applications that demand excellent machining and routing performance along with superior paint-ability for a quality finish.



We proudly bring you yet another versatile product that gives you better performance and utility and satisfies the most stringent of environmental standards. A product for today combining the lowest emission ratings with versatility and quality. **Daiken-Mouldings** is your best choice for internal use.

Produced consistently to stringent quality standards, **Daiken-Mouldings** perform with up to 20% lower thickness swell than standard MDF and meets AS/NZS 1859.2 moisture resistance targets, to further extend the usability of this product.

**Daiken-Mouldings** are available in the full range of certified formaldehyde emission levels, including AS/NZS E0, E1, EPA, TSCA TITLE 6 CARBP2, F3S, F4S, and ULEF.



Furniture, Fittings  
and Flooring  
Licence No. 3215134



CERTIFIED TO JIS & ISO  
F3S & F4S  
Certificate ID No. 07 NZ 01 001



Manufactured in New Zealand and available in a wide range of thicknesses from less than 12mm (0.47 in) up to 25mm (0.98 in), **Daiken-Mouldings** has many uses and applications, including:

- Walls and ceilings
- Vanities and shelving/kitchen panels and cabinets
- Architraves, skirtings' and mouldings
- Substrate for a natural wood veneer, vinyl's, printed papers, foils and melamine papers.

**DAIKEN**  
SOUTHLAND LIMITED

**Daiken Corporation,  
Overseas Trade Section**  
Sumitomo Fudosan  
Akihabara Building  
12-8, Sotokanda, 3-chome  
Chiyoda-ku, Tokyo,  
101-8950 JAPAN  
Tel: +81 3 6271-7650  
info@overseas-daiken.co.jp

**Daiken Shanghai Corporation**  
Room 2301, Ruijin Building,  
205 Maoming Road(s),  
Shanghai 200020,  
China  
Tel: + 86-21-6473-1201

**Daiken Corporation,  
Singapore Branch**  
No. 8 Temasek Boulevard,  
#43-01A, Suntec City Tower 3,  
Singapore 038988  
Tel: (65) 6297 1933  
singapore@daiken.co.jp

## Daiken-Mouldings

Aim Properties when tested to JIS A 5905 \*Based on 1220x2440 panel size.

Product	Internal Bond (MPa)	Average Density (kg/m <sup>3</sup> )	Thickness (mm)	Thickness Swell (%)	Weight (kg/m <sup>2</sup> )* per sheet	Wood Species
Daiken-Mouldings	≥ 0.8	≥ 730	12	≤ 12	8.8	New Zealand Radiata Pine
	≥ 0.7		18	≤ 7	13.1	
	≥ 0.7		25	≤ 7	18.3	

For details on panel sizes, thicknesses and weight, please see [www.daikensouthland.co.nz](http://www.daikensouthland.co.nz), or talk to your Daiken Sales Representative.

### Daiken mouldings

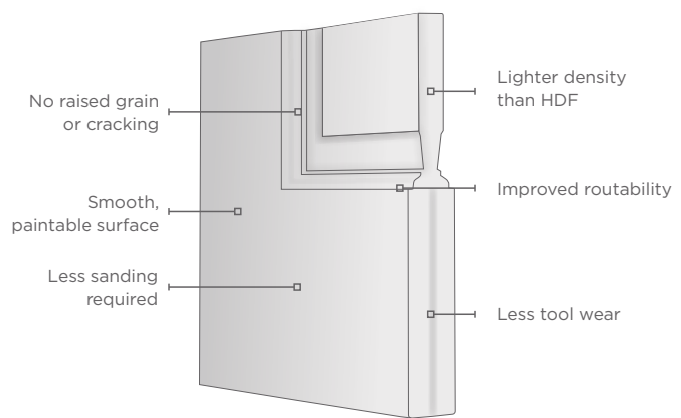

### Routed Roughness

Daiken Mouldings are specifically engineered to have less roughness after routing when compared to lighter density products.

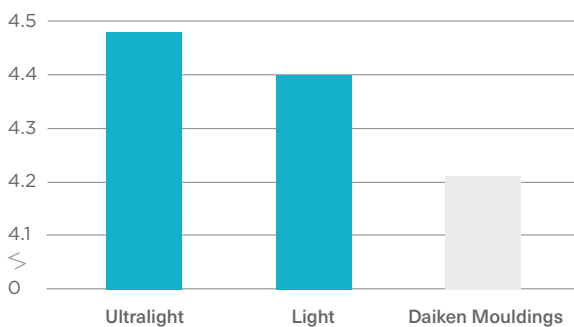

### Competitor's mouldings

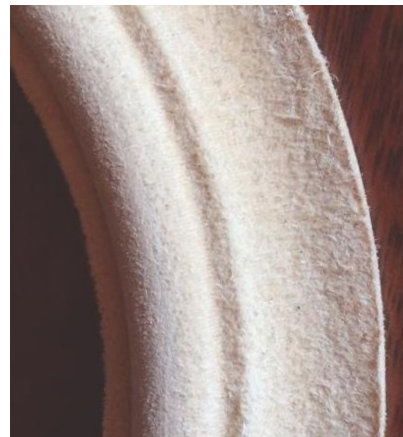

Superior machinability, a smooth finish and reliable moisture resistance at a lower density than HDF mouldings allows you to reduce your running and logistics costs, and enjoy easier and safer handling. Our expert refinements to resin chemistry means better tooling and paint-ability compared to HDF mouldings: **Daiken-Mouldings**.

